

Heraeus

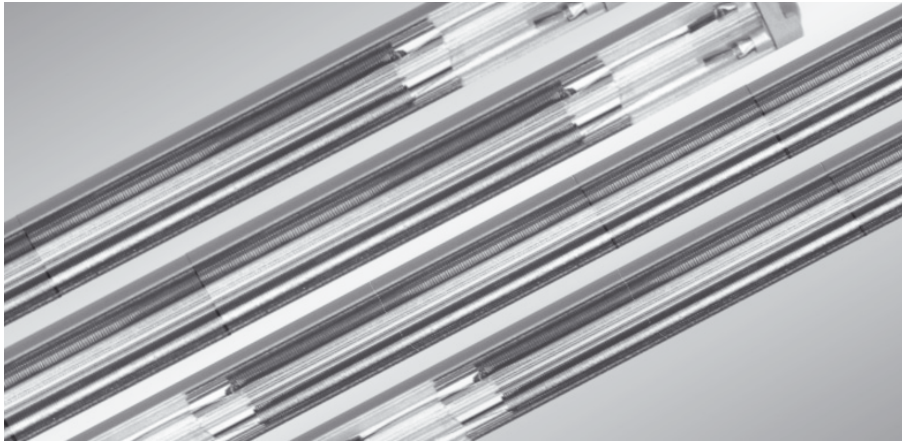

**IR-twin-tube emitter
medium-wave
Operating instructions**

Heraeus Noblelight

Contents

1. Safety instructions	3
3. Transport	4
2. Area of application	4
4. Assembly	5
5. Electrical connection	6
6. Maintenance	6
7. Accessories	7

1. Safety instructions

Infrared emitters basically consist of pure quartz glass and a heating spiral.



There is a possibility that quartz glass of the emitters may either break or chip off. (Glass splinters in the emitter cannot always be clearly seen). Users might hurt themselves on the broken emitter glass. Quartz glass splinters may drop on the materials to be exposed to radiation. In order to avoid damage to property or injuries to persons, the machine manufacturer/operator must take appropriate measures (as regards the design/maintenance intervals).



Infrared radiation is an intensive heat source!
Extreme heat radiation of this type may harm the human body as a result of the heat produced in the absorption process (comparable to danger from an open or blazing fire).

The most immediate risk is of IR erythema (skin burns). Additionally, medical studies have emphasised that the use of IR radiation, particularly when over-used for years or decades, can damage the cornea and the lens, causing an IR cataract.

To protect the machine operator from the heat produced by the IR emitters during the heating process, the DIN EN 12198 Directive "Machine Safety: Evaluation and Risk Reduction from Radiation-emitting Machines" was established, which serves as the basis for categorising the IR radiation emitted by machines and also lists the measuring procedures and safety and protection measures to be taken (e.g. housing of IR emitter, IR protective filter in accordance with DIN EN 171 as personal eye protection).

The machine directive should be taken into account by the machine manufacturer when designing machines using IR light as a heat source.



If a potentially explosive atmosphere can be formed (resulting from solvent vapour/air mixtures), the relevant standard EN 1539 must be observed since there is a risk of ignition at the infrared twin-tube emitter (the solvent vapour concentration must be below 25% of the lower explosion threshold). Released vapours must be expelled at the installation site by the customer. The safety regulations for coating material processes (Germany: BGV D 25) must be observed.

The safety and function of the IR Heating System are guaranteed only if original parts and replacement parts from HERAEUS Noblelight are used.



Disregard of the safety regulations or improper operation of the Infrared Heating System can lead to injuries and material damage.

2. Area of application

The IR twin-tube emitter may be used only for industrial heating and drying processes (General safety regulations according to EN 60519-1/DIN VDE 0721, part 911).
Thermal safety: Category 0 according to EN 60519-2/VDE 0721, part 411 (monitored operation with non-hazardous charging material only).

The IR twin-tube emitter must be operated with a supply voltage no higher than its nominal voltage.

Depending on the installation conditions (particularly with a heat build-up and the radiation direction from above downward), the IR emitter must be cooled so that:

- when using the IR emitter continuously, a temperature of 600°C on the gold reflector surface should not be exceeded.
- the insulated connection lead has a maximum permissible operating temperature of 230°C and a standard length of 500 mm.

The maximum permissible operating temperature, after taking into account the heat losses of the electrical current and any possible heat dissipation (layout type, installation conditions), must not be exceeded.

Experience indicates that the permissible operating temperature for an individual lead will be reached at an ambient temperature of 150°C in the absence of any air flow.

3. Transport

Transport the IR emitter in the packaging provided to the place of installation.

If the IR emitter must be transported without its packaging, wear linen gloves.

Fingerprints on the quartz tube will cause devitrification. These lead to radiation losses and mechanical failure.

- Carry the emitter with both hands to prevent it bending.
- Do not grip the IR emitter on just one side nor carry it by its cable end. Avoid any pressure on the flat base.

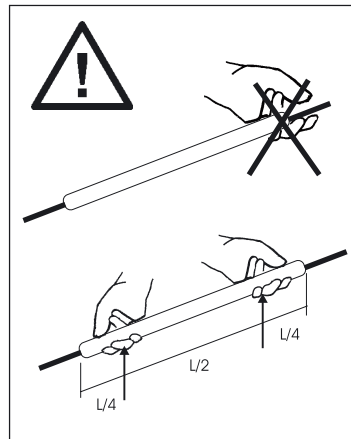

4. Assembly

The infrared twin-tube emitter is suited for **horizontal** operation only. Special IR emitters for vertical installation positions are **specially** manufactured and marked as such.

To install our IR emitters, usually **one** clamp mounting and **one** spring mounting, and if necessary, **one** or **several** central supports all manufactured by HNG are to be used.

The IR twin-tube emitter must be secured in position with the clamp springs (see accessories) of a stable support (steel support plate: ≥ 1.5 mm).

The IR emitter(s) must be assembled in the following order:

- Drill mounting holes with $\varnothing 9.2$ mm for clamp holder and retaining spring in the support (mounting plate) at distance L.
- Screw the clamp holder and retaining spring in place with ceramic washers (1) and support angle (5) on the mounting plate (4).
- Press the IR emitter into clamp holder and retaining spring by rotating it around its longitudinal axis. The gold reflector should be pointing towards the support plate.
- Push the support angle (5) to the ceramic of the emitters, tighten the fastening nuts (2) and the knurled nut (3).
- Pulling the connection cable must not cause any tension on the flat base.
Bending radius of connection cable: > 30 mm

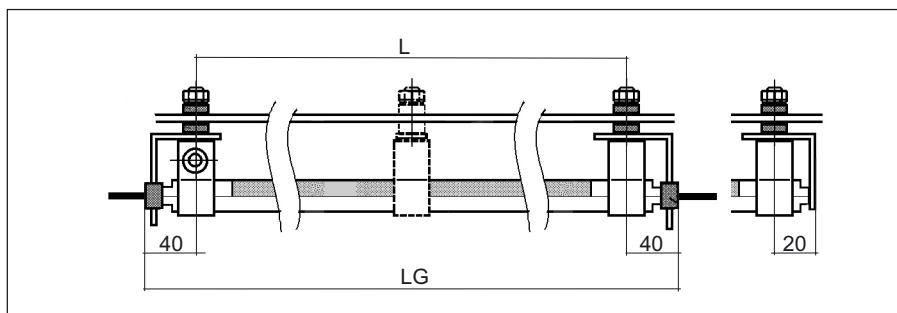
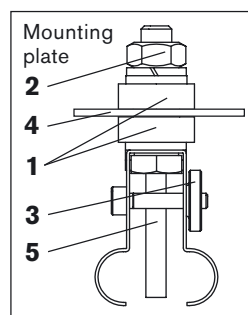

Mounting dimensions:

L = Overall length of emitter LG - 2x40 mm (two-sided connection) or

L = Overall length of emitter LG - 40 mm - 20 mm (one-sided connection)

i If the following overall emitter lengths are exceeded LG, a central support is necessary:

Tube dimensions: 18 x 8, LG > 1000 mm, 22 x 10, LG > 1500 mm and 33x15, LG > 2000 mm

After installation, the quartz glass tube of the IR emitter must be cleaned on the side without gold plating. For this purpose, please use the cleaning cloth included in our delivery or a clean linen cloth (without textile finishing agents) soaked in methylated spirit to remove any impurities/soiling or fingerprints from the surface.

i The gold-plated side must not be cleaned.

5. Electrical connection

The electrical connection of the IR twin-tube emitter must be carried out by authorised skilled personnel in compliance with the relevant safety regulations (in Germany, for example, the electrical engineering standard DIN VDE 0100 and the safety regulations UVV BGV A 2 "Electrical Systems and Operating Equipment").

Lead the cable ends of the IR twin-tube emitter to the junction box without bunching them and cut them to the required length if possible.

Fit a cable sleeve to the bare connection end of the cable.

Following the electrical connection, the IR twin-tube emitter must be checked according to EN 60519-2/VDE 0721, part 411 "Industrial Electrical Heating Systems" (equipment and accessories).

Due to its design, the IR twin-tube emitter has a certain output tolerance range.

This is why after the installation of one or several emitters into a system, its/their overall power consumption must be checked to ensure compliance with the specifications.

6. Maintenance

The IR twin-tube emitter is maintenance-free. We recommend, however, that you check the function and cleanliness of the IR emitter regularly (especially the quartz glass).

Soiled quartz glass should be cleaned. Proper function of the emitter is only ensured if the quartz glass remains clean.

Defective IR twin-tube emitters should be replaced.

If you have any queries, contact Heraeus Noblelight.

7. Accessories

Designation	Part number	Tubing format in mm	Dimensions in mm				Fixing bolt
			a	b	c	d	
Clamp holder	0975 8010	18x8	18	8	32,2	36,2	M5
Retaining spring	0975 8011				32,2	36,2	
Central support	0975 8012				30,7	34,7	
Clamp holder	0975 8013	22x10	22	10	32,2	37,2	M5
Retaining spring	0975 8014				32,2	37,2	
Central support	0975 8015				30,7	35,7	
Clamp holder	0975 8016	33x15	34	15	37,2	44,7	M6
Retaining spring	0975 8017				37,2	44,7	
Central support	0975 8018				35,7	43,2	

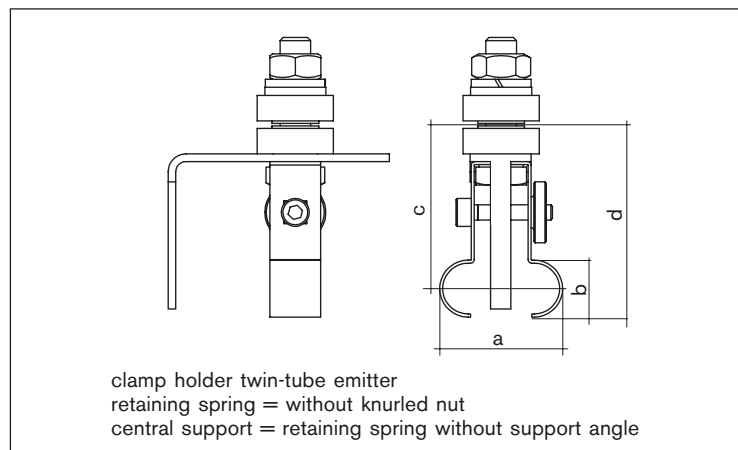



Heraeus Noblelight GmbH
Reinhard-Heraeus-Ring 7,
63801 Kleinostheim / Deutschland

eMail: hng-infrared@heraeus.com
Internet: www.heraeus-noblelight.com

Technische Änderungen vorbehalten.
We reserve the right to technical modification.
Sous réserve de modification techniques.

© „Copyright reserved“
© „Tous droits réservés“.
TDN 04.04